

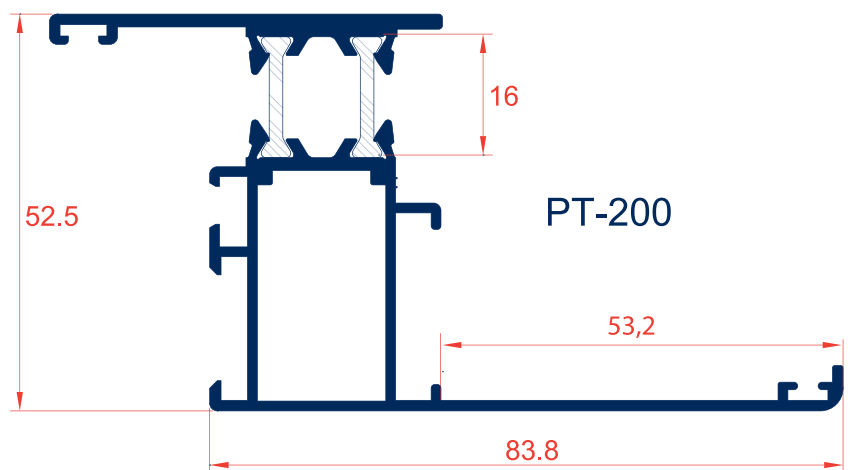

THERMO 52

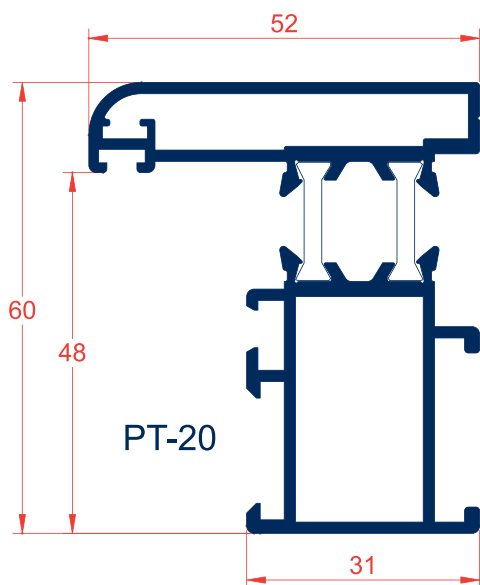

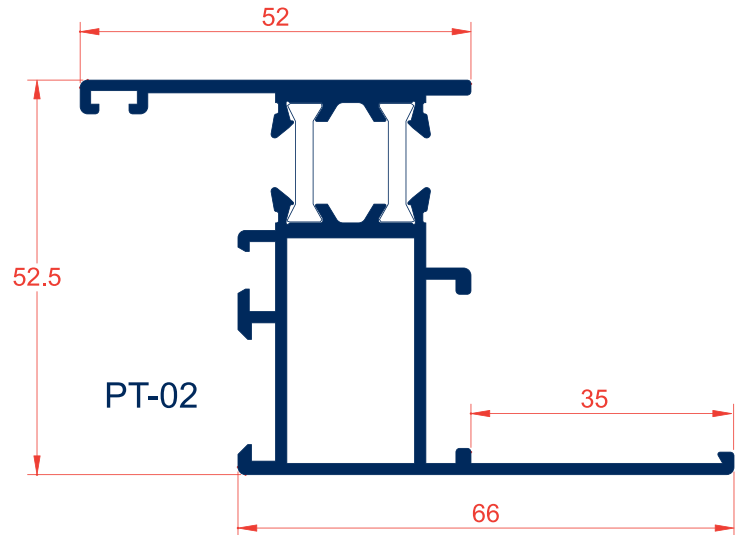

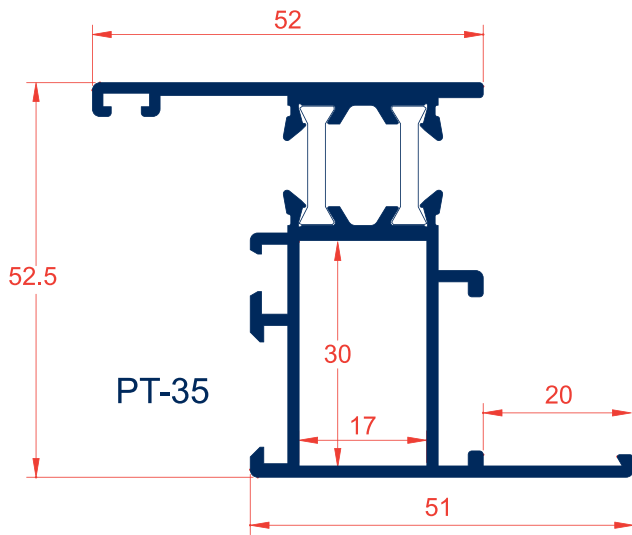
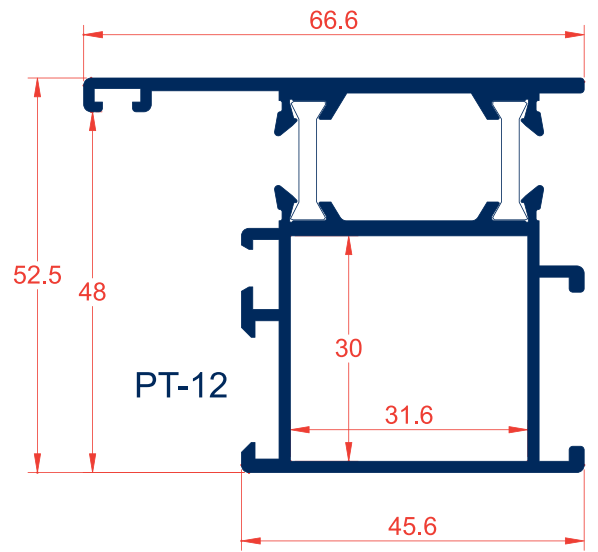
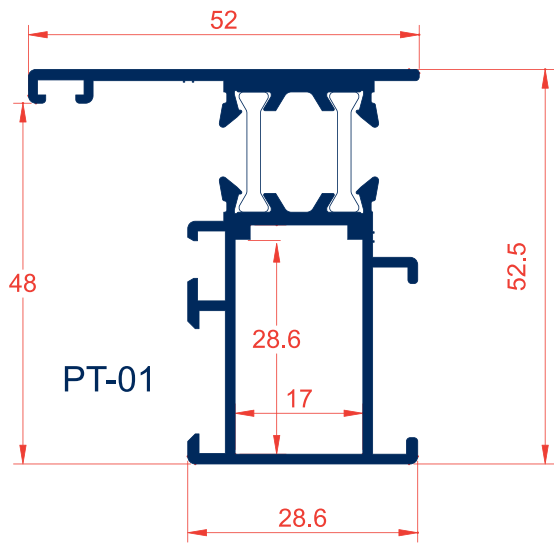
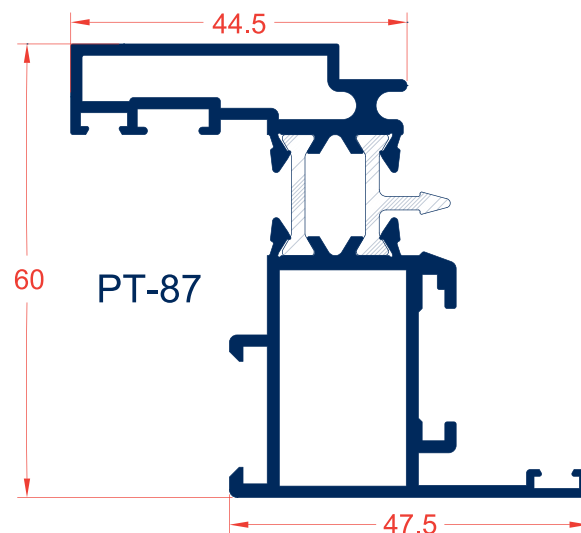
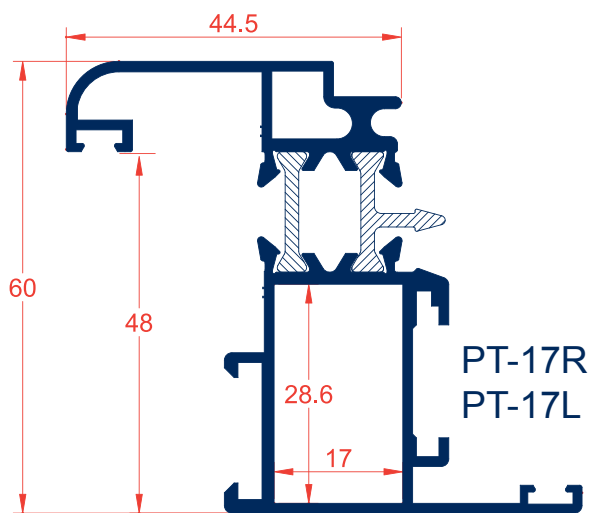
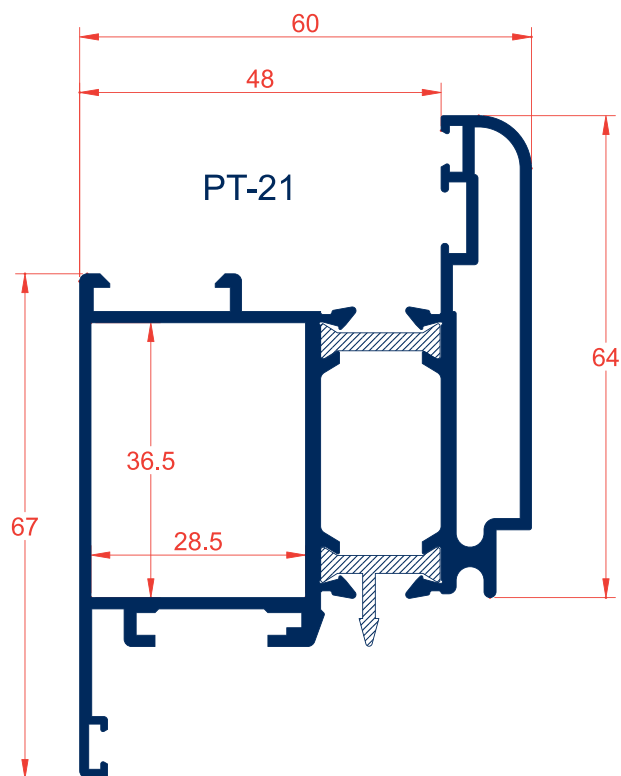
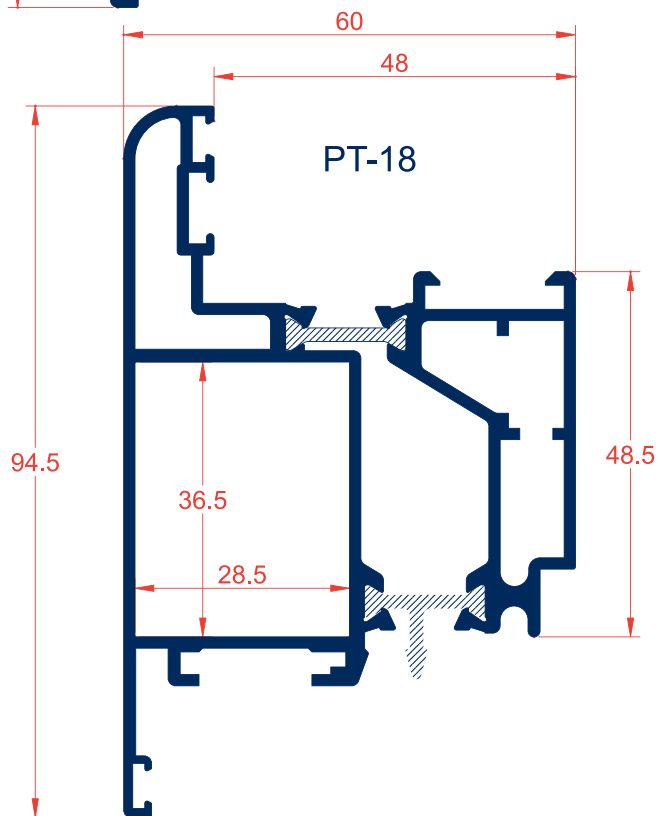
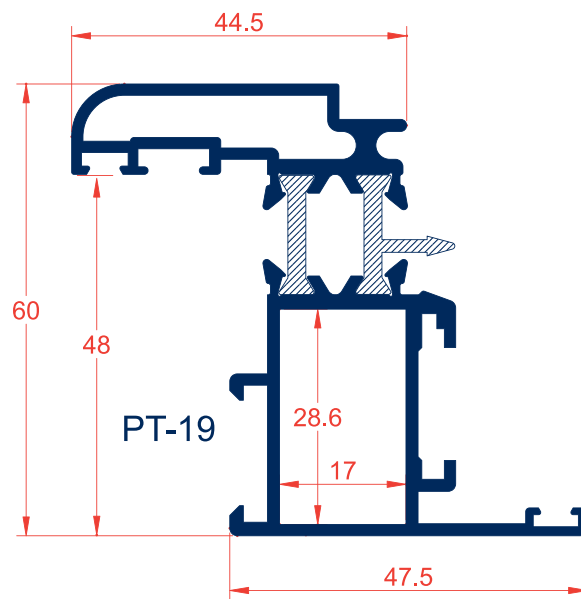
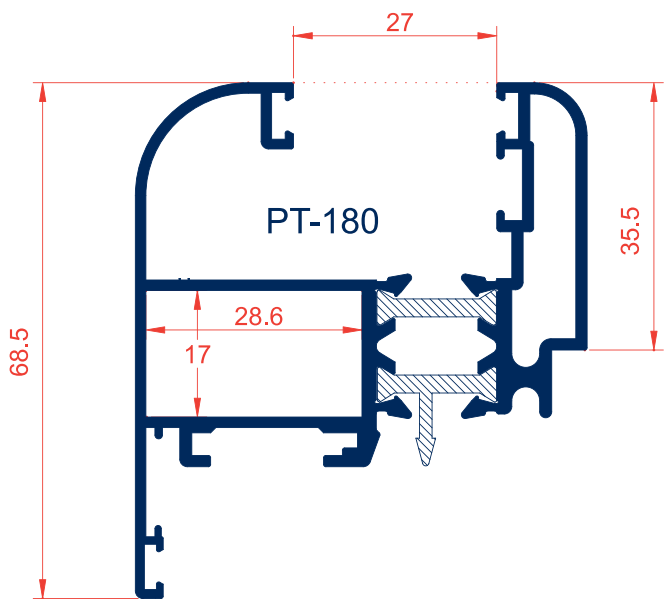
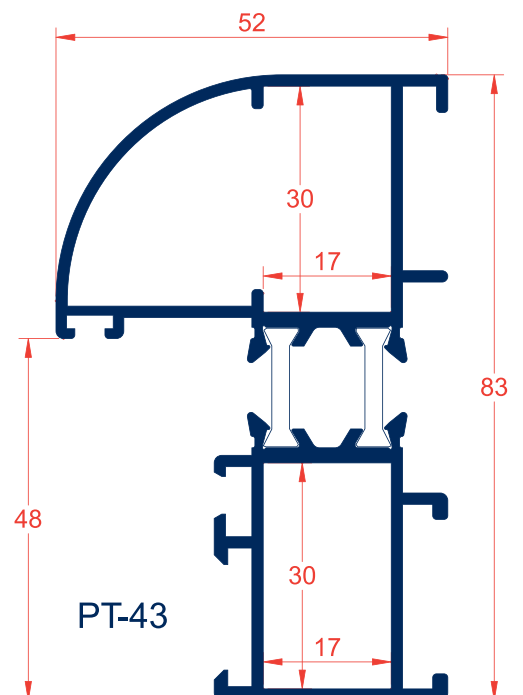
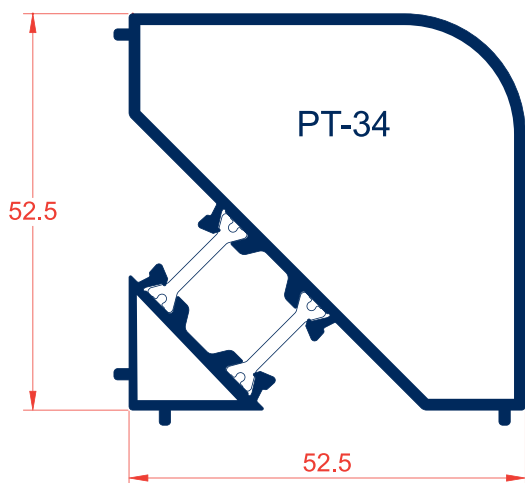
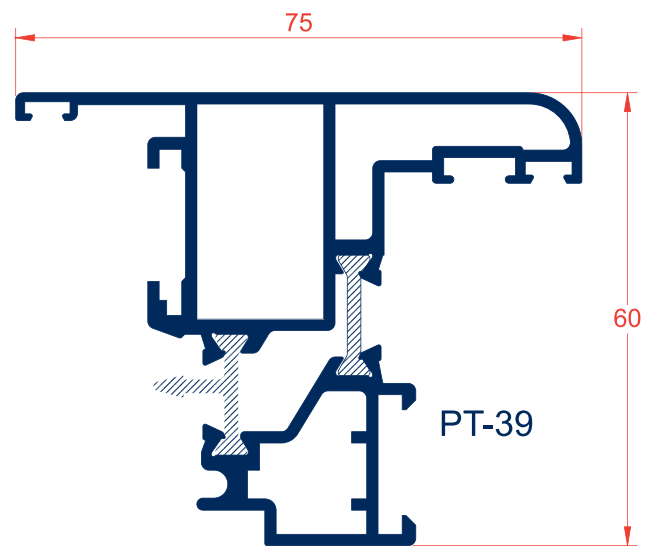
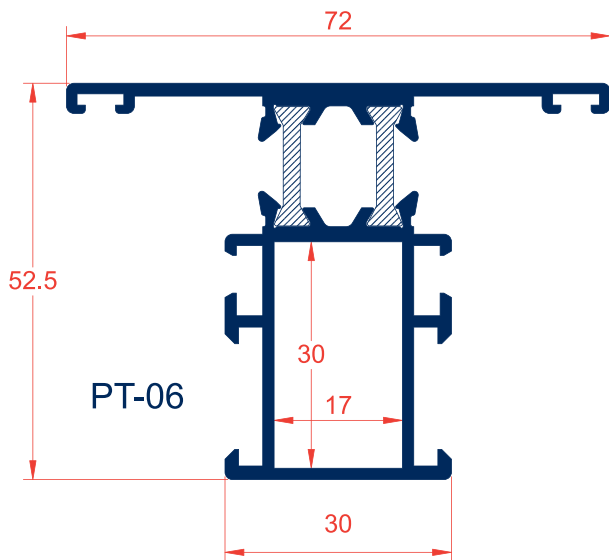
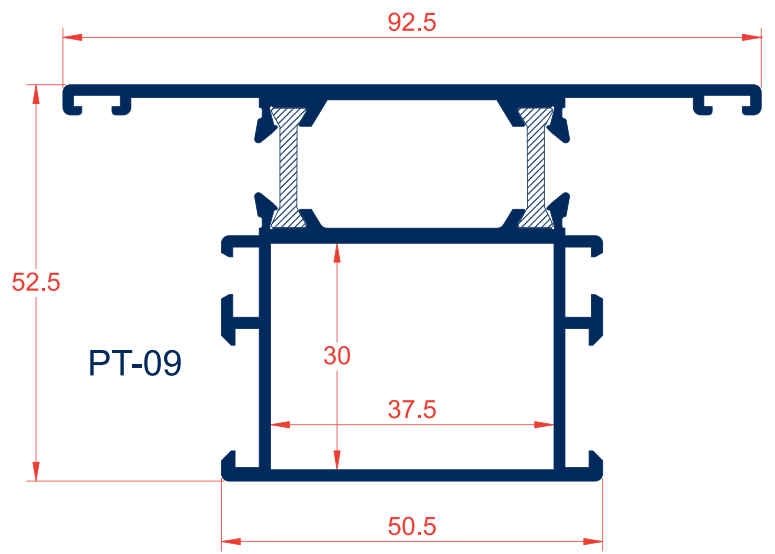
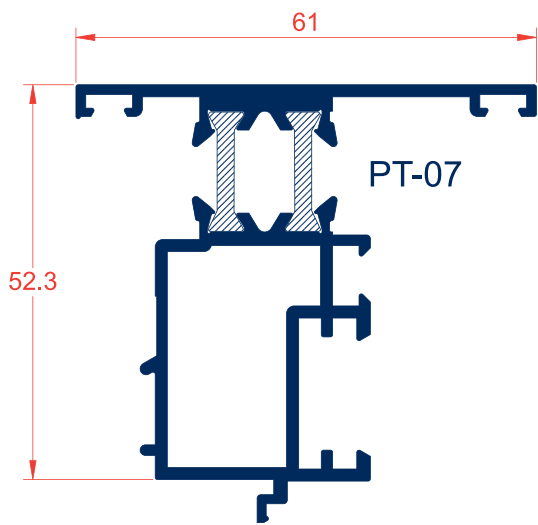

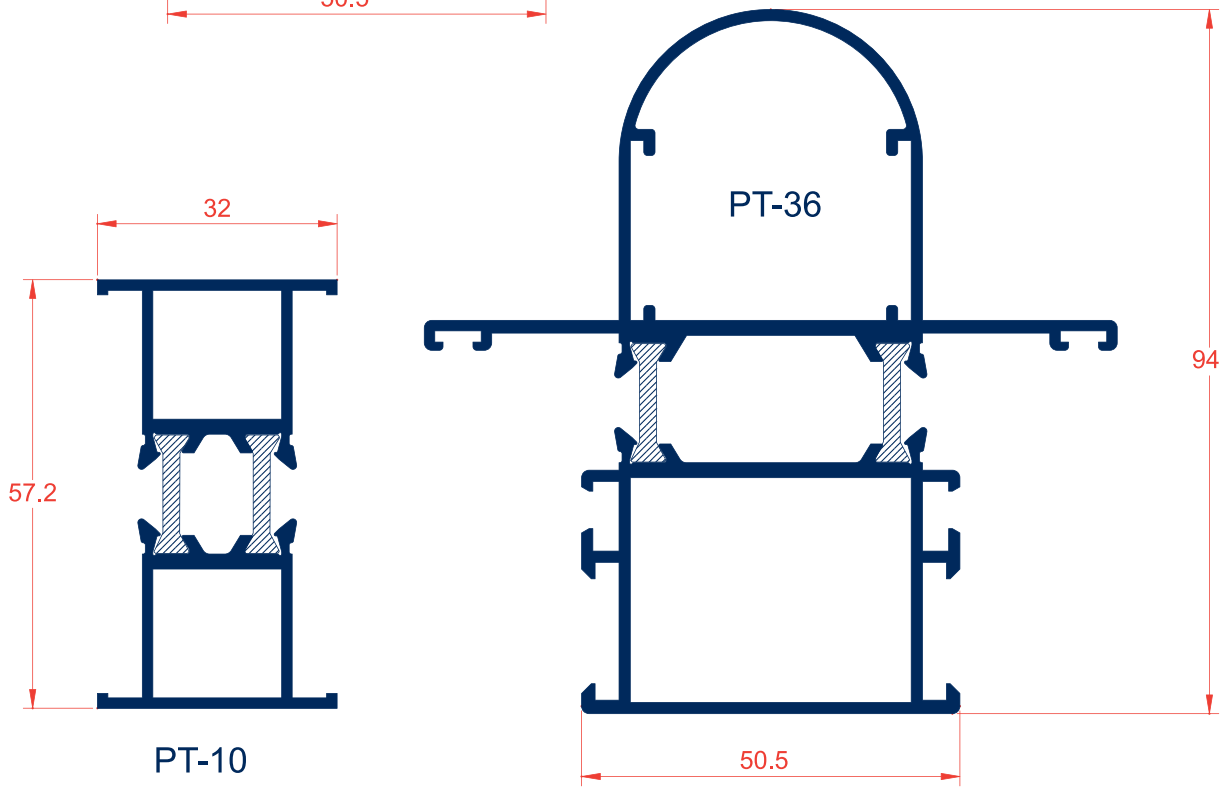
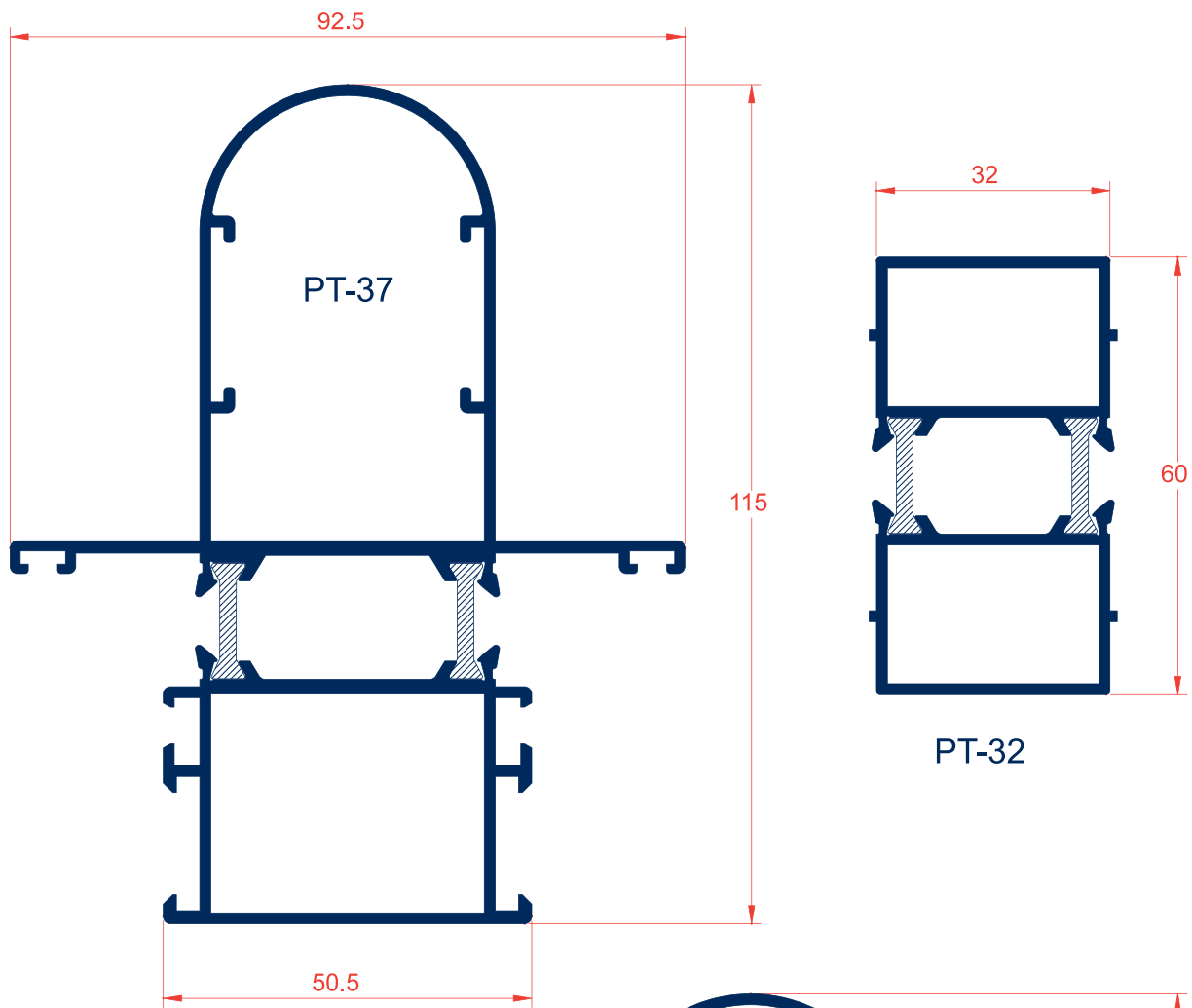

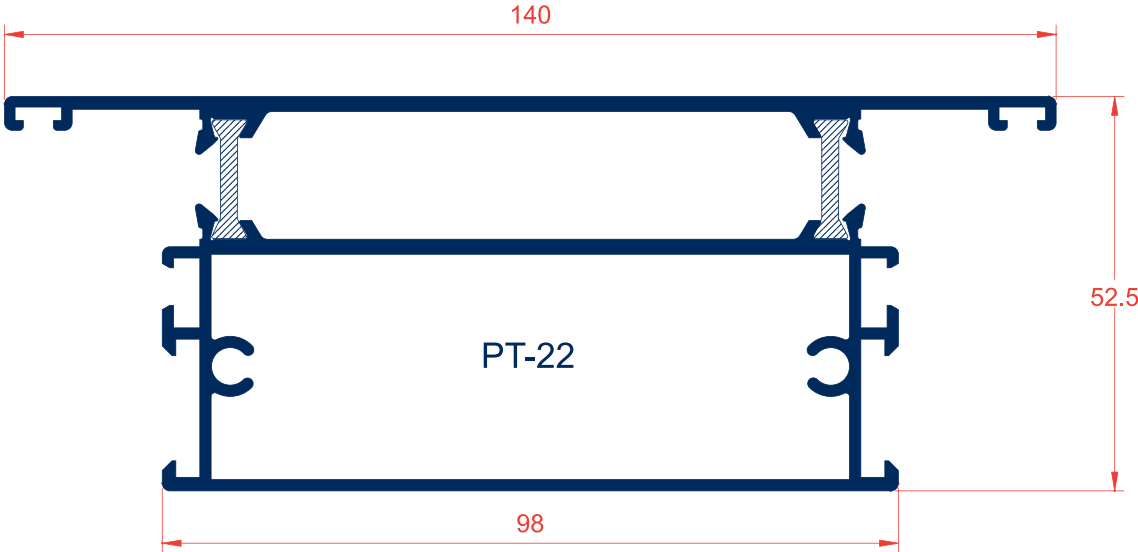
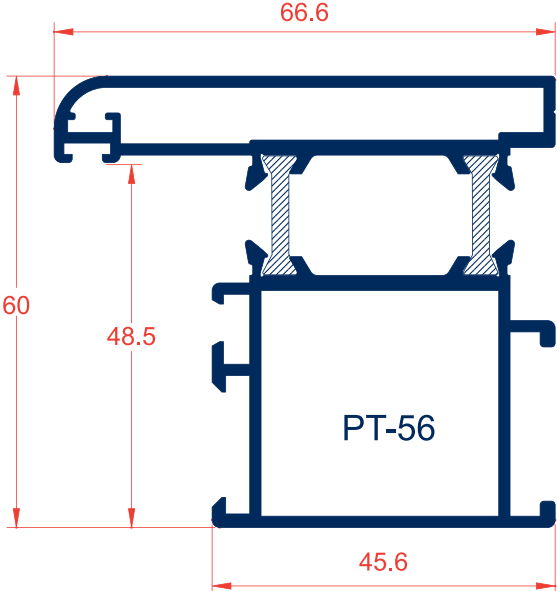

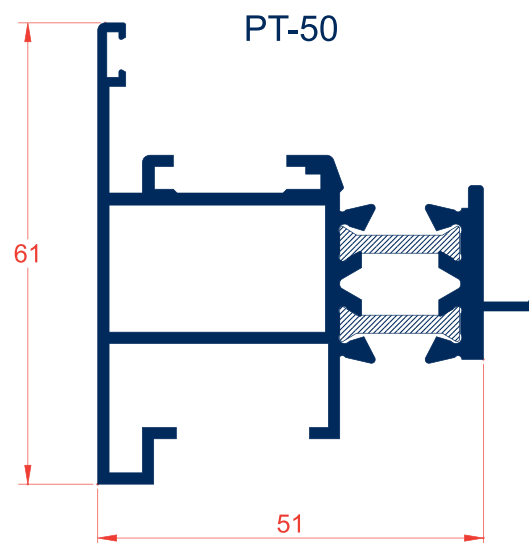
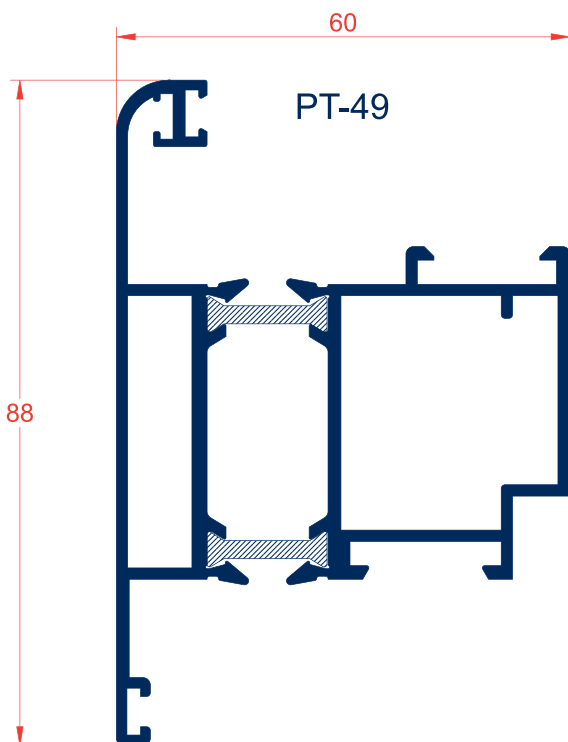
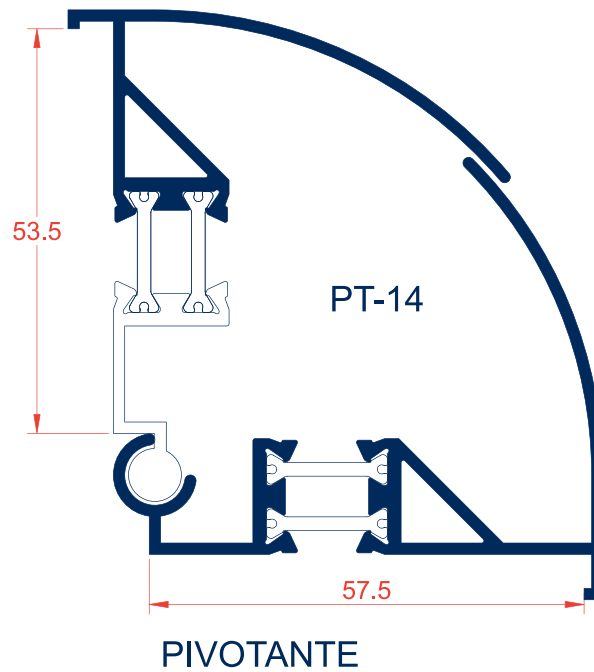



















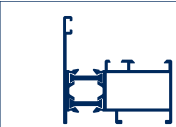
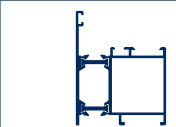
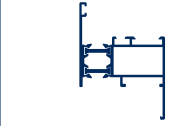
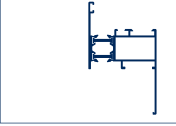
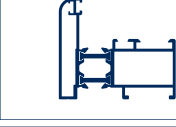
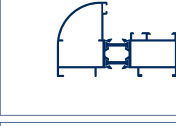
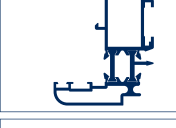
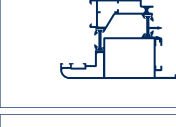
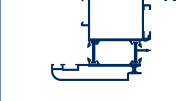

		 7637	 7615	 7613	 7614	 7504	 7505	
		 4284	 7634	 7525	 7530	 7724	 7498	
		 11.285	 7280	 7671	 7281	 7282	 7310	 7361
 PT-01	44	35	32	27	23	20	14.5	
 PT-12	44	35	32	27	23	20	14.5	
 PT-35	44	35	32	27	23	20	14.5	
 PT-02	44	35	32	27	23	20	14.5	
 PT-20	44	35	32	27	23	20	14.5	
 PT-43	44	35	32	27	23	20	14.5	
 PT-19	44	35	32	27	23	20	14.5	
 PT-18	44	35	32	27	23	20	14.5	
 PT-21	44	35	32	27	23	20	14.5	

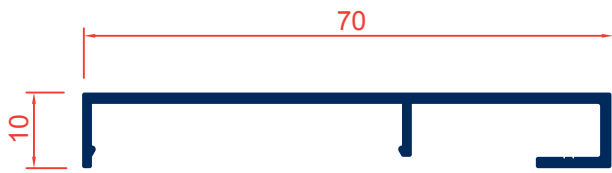

Ref. 14.209
kg.- 0.408
P.- 208

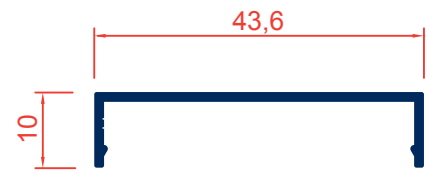

Ref. 14.210
kg.- 0.216
P.- 126

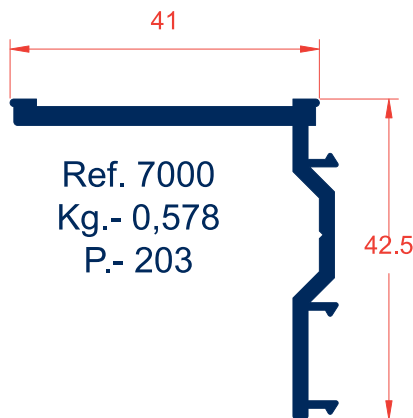

Ref. 7000
Kg.- 0,578
P.- 203

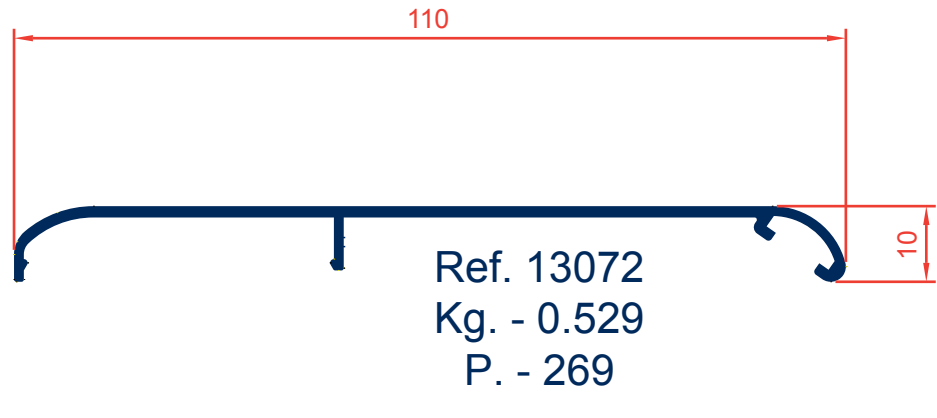

Ref. 13072
Kg. - 0.529
P. - 269

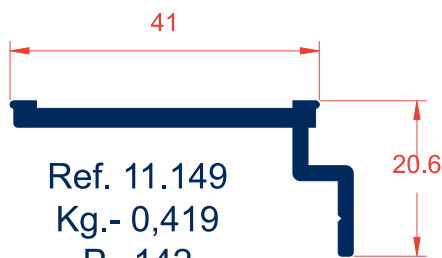

Ref. 11.149
Kg.- 0,419
P.- 142

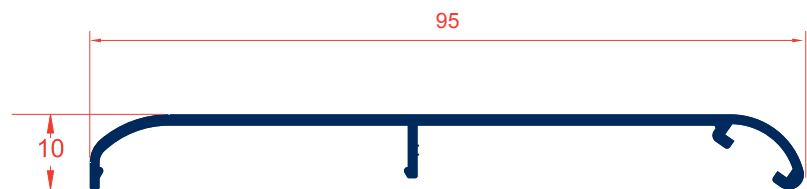

Ref. 11697
kg.- 0,478
P.- 251

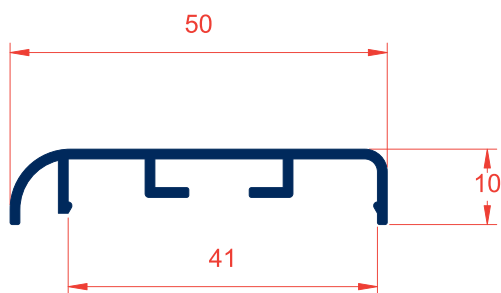

Ref. -4228
Kg.- 0,319
P.- 187

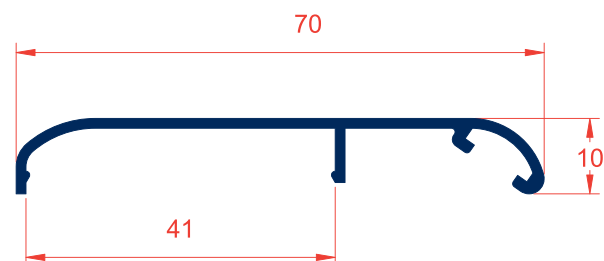

Ref. 7539
Kg.- 0,348
P.- 195

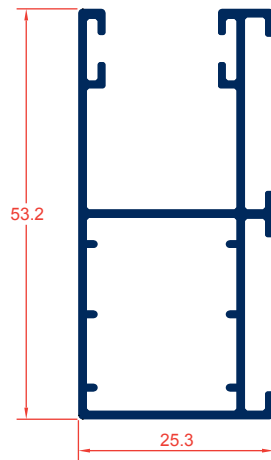

Ref. 4286
kg.- 0.578
P.- 388

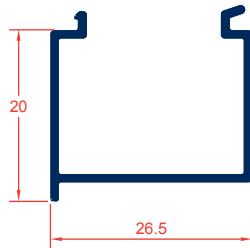

Ref. 4289
kg.- 0.246
P.- 166

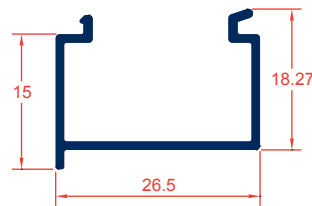

Ref. 4290
kg.- 0.216
P.- 145

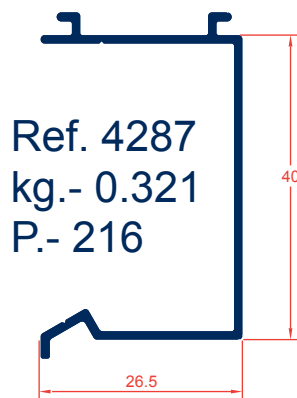

Ref. 4287
kg.- 0.321
P.- 216

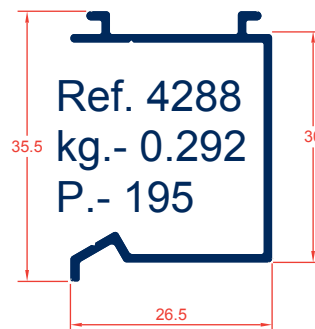

Ref. 4288
kg.- 0.292
P.- 195

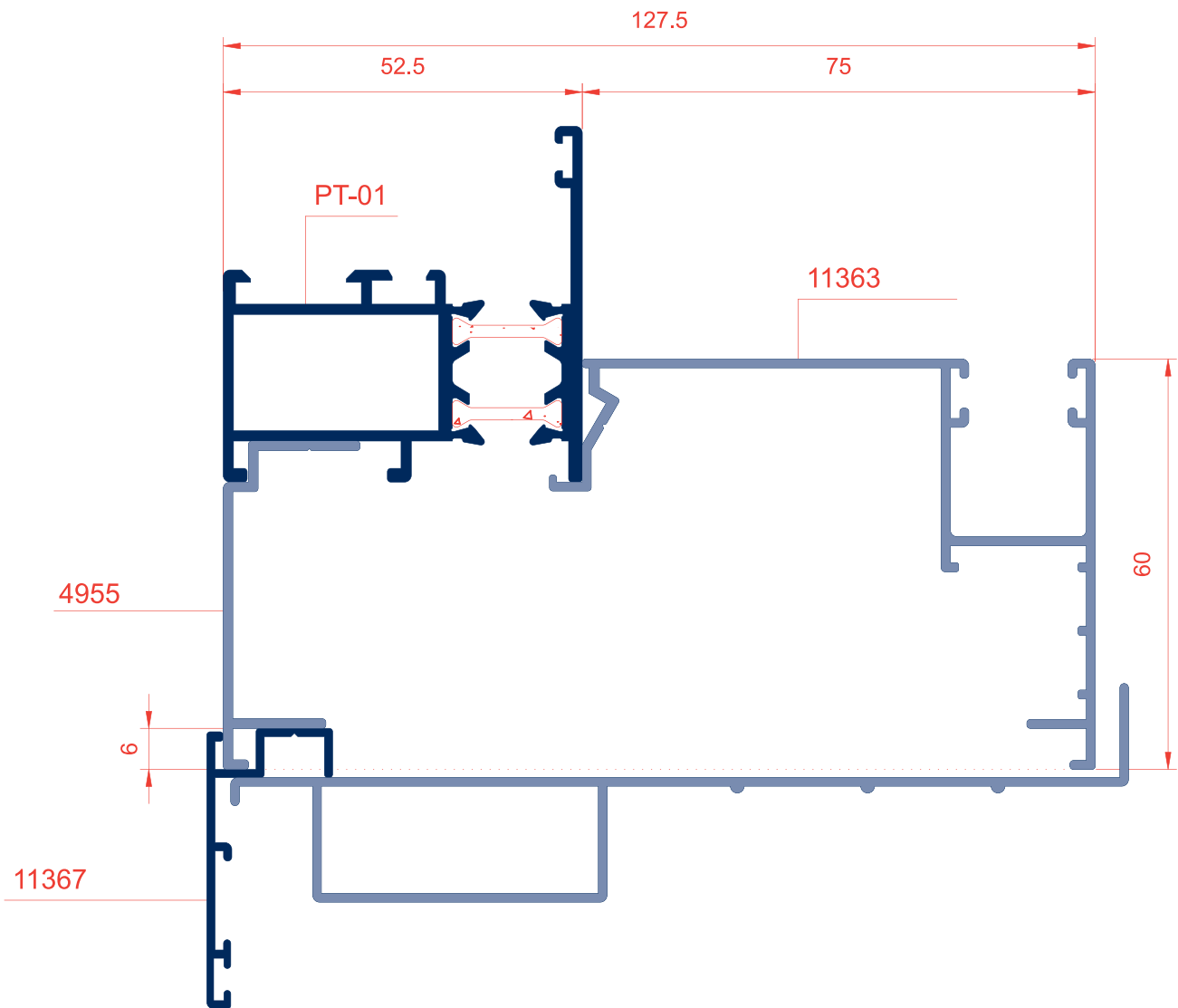

Ref. MARCO	Ref. GUÍA	MEDIDA GUÍA	TOTAL
PT-01	11.455	48 mm.	100,5 mm.
PT-01	11.748	67,5 mm.	120 mm.
PT-01	4.528	70 mm.	122,5 mm.
PT-01	11.363	75 mm.	127,5 mm.
PT-01	4.959	77,7 mm.	130,2 mm.
PT-01	11.364	80 mm.	132,5 mm.
PT-01	4.960	85,7 mm.	138,2 mm.
PT-01	11.263	110 mm.	162,5 mm.
PT-01	11.365	120 mm.	172,5 mm.

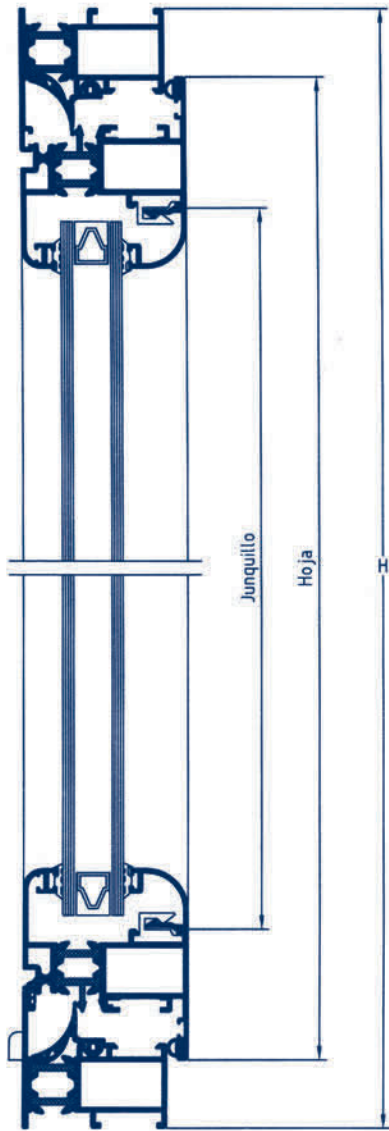

SECCION B - B

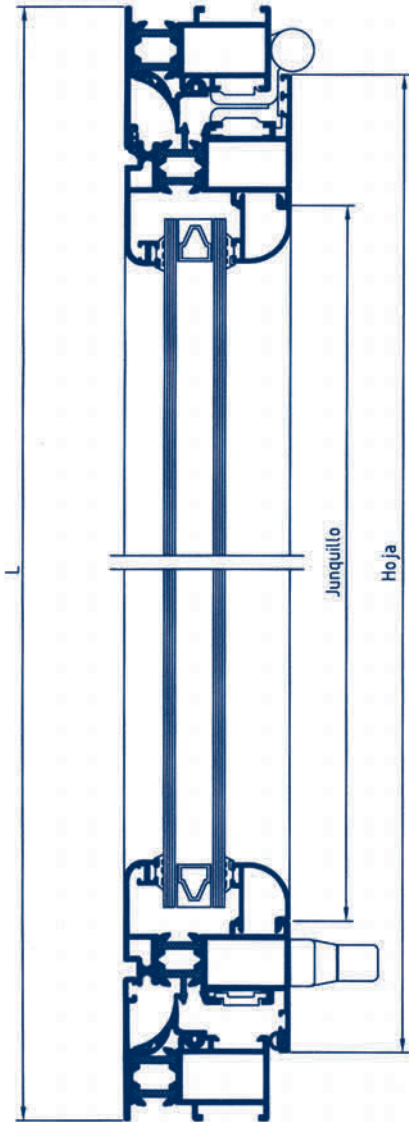

SECCION A - A

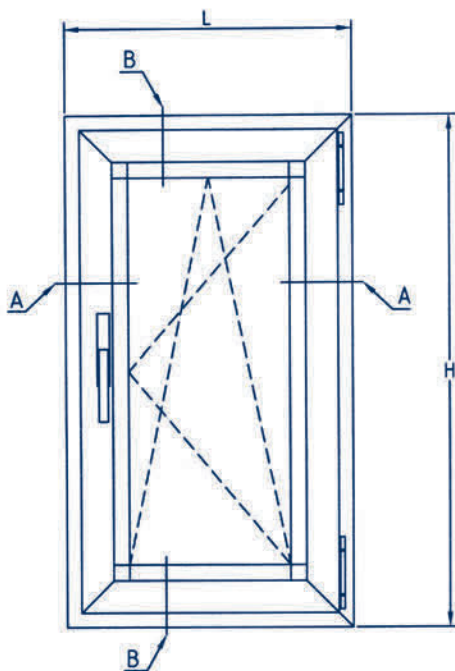

CROQUIS	REFERENCIA	DENOMINACION	Tipo de corte	Cantidad	Medida
	PT-01	Marco ventana		2 2	L H
	PT-17	Hoja ventana		2 2	L-50 H-50
	7613	Junquillo redondo hueco de 27 mm.		2	H-145
	7525	Junquillo redondo clip hueco de 27 mm.		2	L-145
	7013	Pletina cremona		-	-

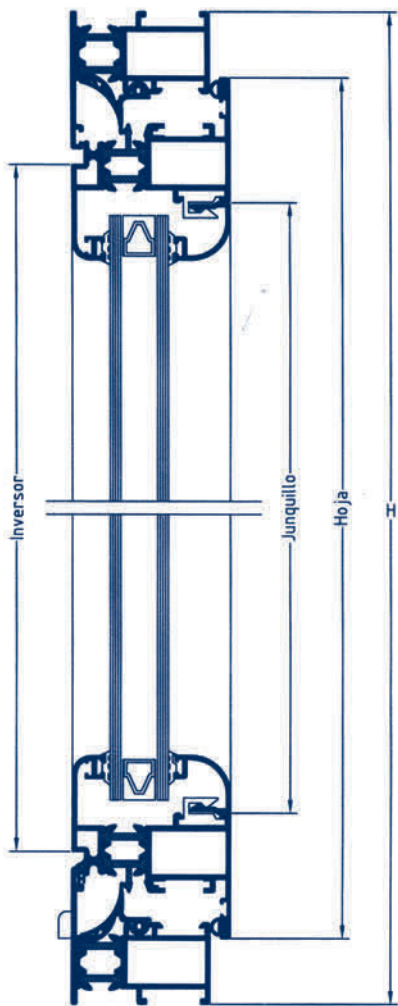

SECCION B - B

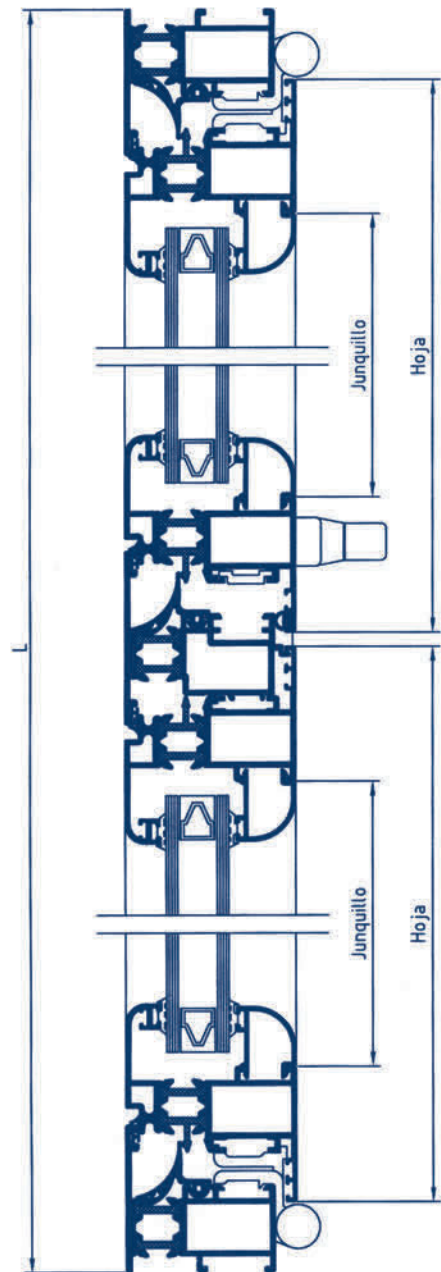

SECCION A - A

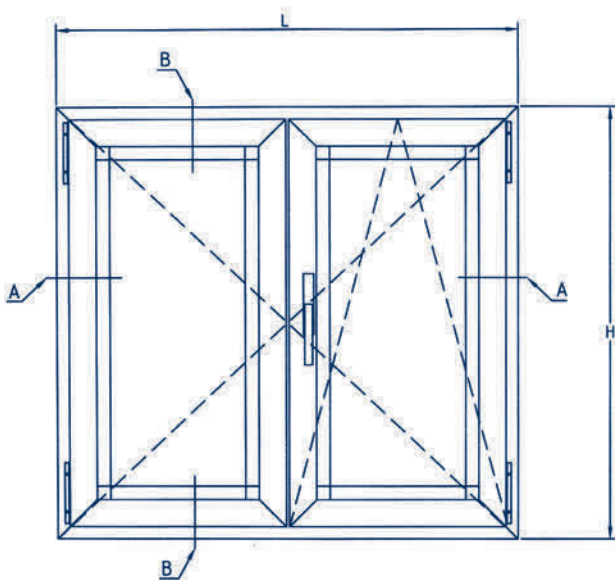

CROQUIS	REFERENCIA	DENOMINACION	Tipo de corte	Cantidad	Medida
	PT-01	Marco ventana		2 2	L H
	PT-17	Hoja ventana		4 4	L-55/2 H-50
	PT-07	Inversor		1	H-116
	7613	Junquillo redondo hueco de 27 mm.		4	H-146
	7626	Junquillo redondo clip hueco de 27 mm.		4	L/2-122.5
	7013	Pletina cremona		—	—

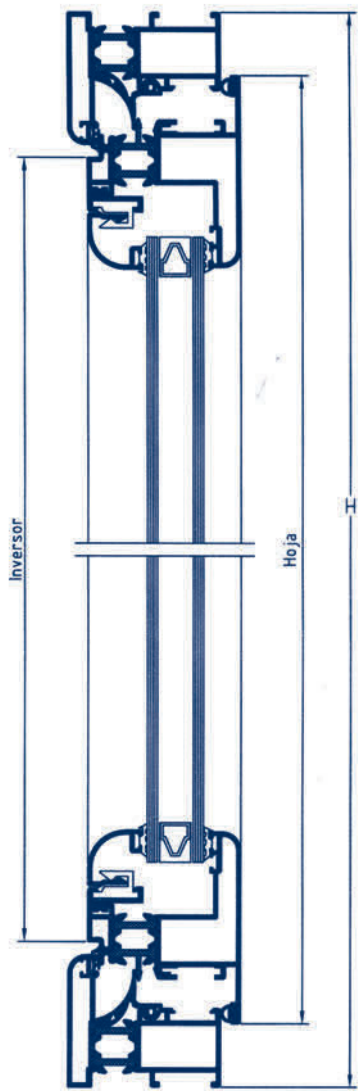

SECCION B - B

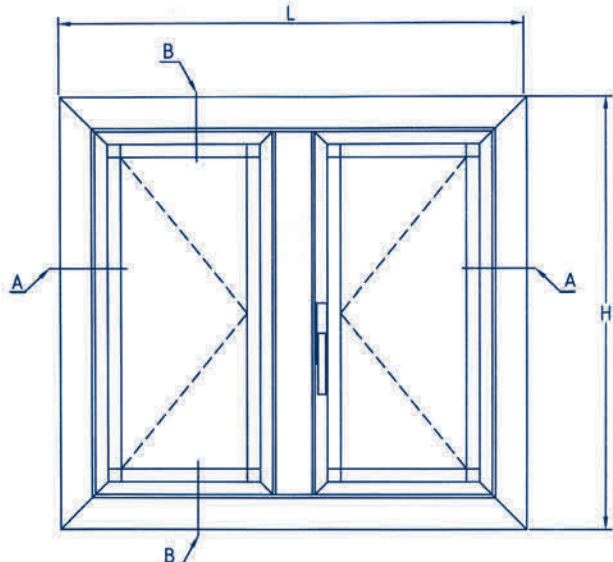
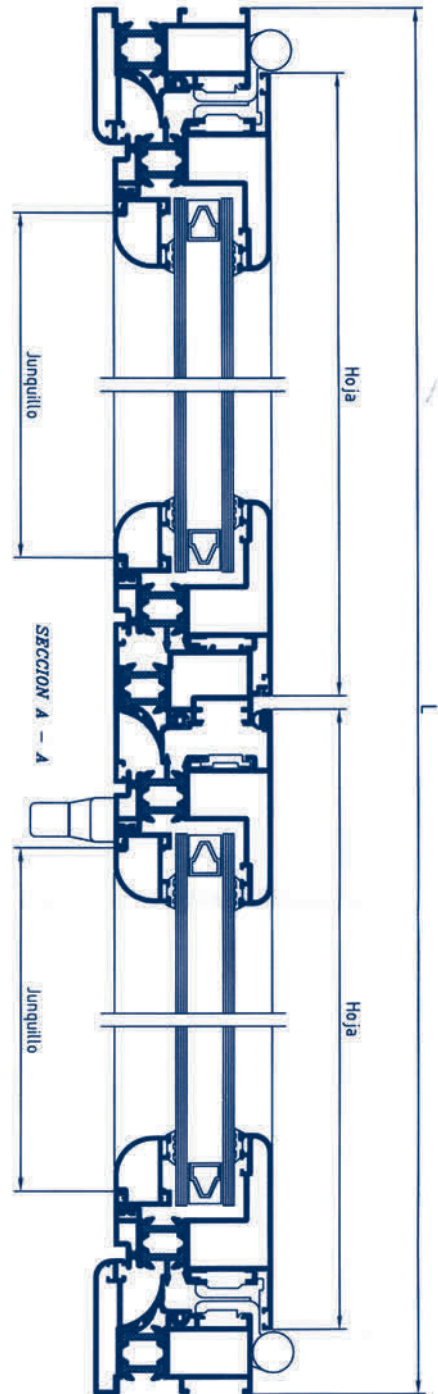

CROQUIS	REFERENCIA	DENOMINACION	Tipo de corta	Cantidad	Medida
	PT-20	Marco ventana		2 2	L H
	PT-39	Hoja ventana apertura exterior		4 4	L-55/2 H-50
	PT-07	Inversor		1	H-122
	7613	Junquillo redondo hueco de 27 mm.		4	H-156
	7525	Junquillo redondo clip hueco de 27 mm.		4	L/2-133.5
	7013	Pletina cremona		—	—

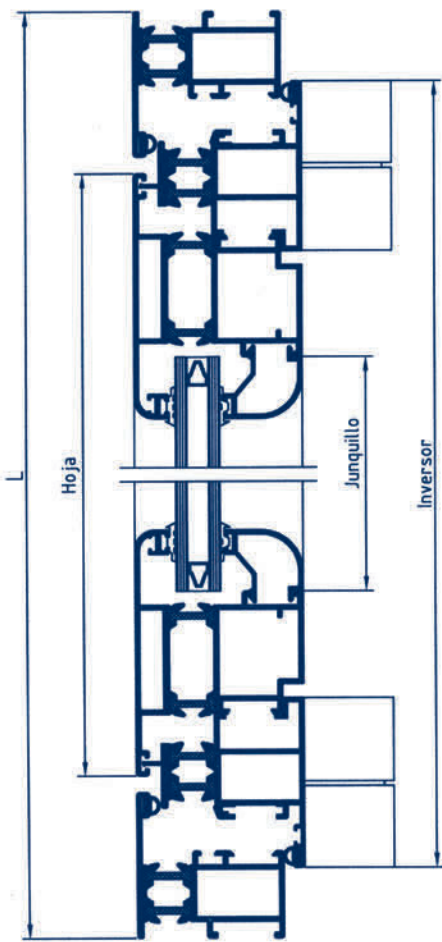

SECCION A - A

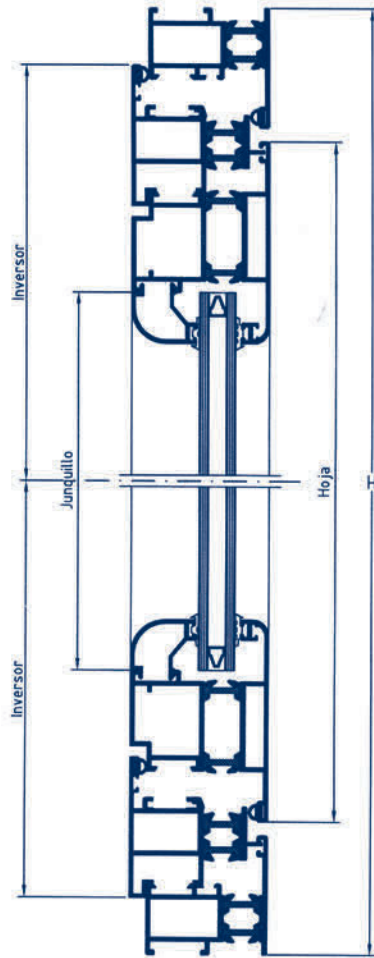

SECCION B - B

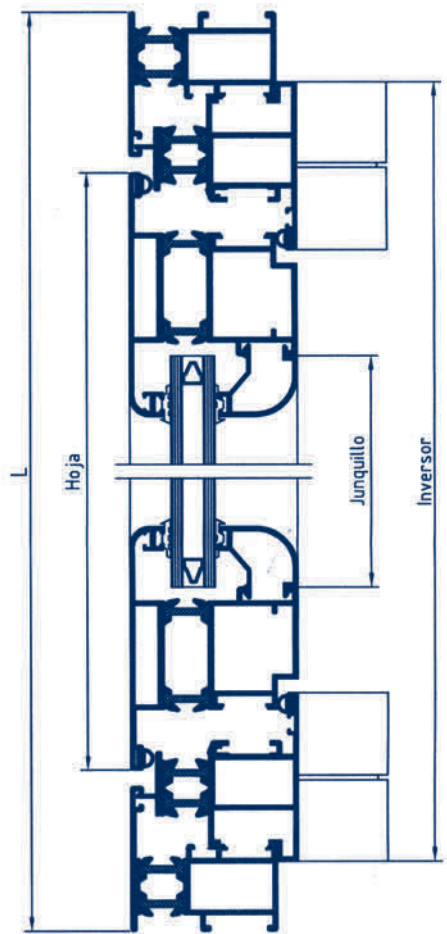

SECCION C - C

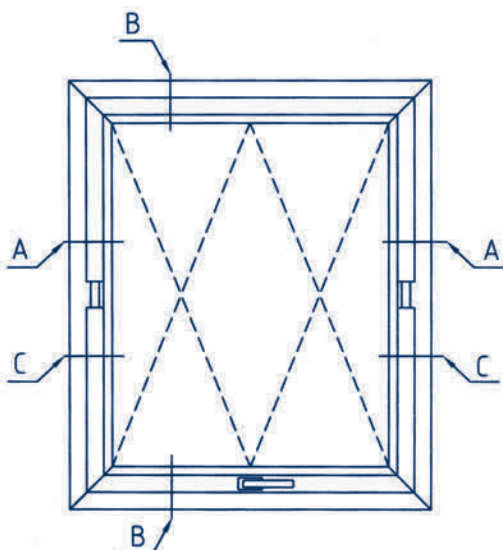

CROQUIS	REFERENCIA	DENOMINACION	Tipo de corte	Cantidad	Medida
	PT-01	Marco ventana		2 2	L H
	PT-49	Hoja		2 (A-A) 2 (B-B) 2 (C-C)	L-116 H-116 L-116
	PT-50	Inversor		2 (A-A) 2 (B-B) 2 (C-C)	L-50 H/2-50 L-50
D	7613	Junquillo redondo hueso de 27 mm.		2 (A-A) 2 (B-B) 2 (C-C)	L-248 H-248 L-248